



2024-2025

# CATALOG

---

Engineering Excellence,  
Building Trust

[www.sistemteknik.com](http://www.sistemteknik.com)

# TABLE OF CONTENTS

ALUMINUM &  
SUSTAINABILITY

4

ABOUT ST

7

COMMITMENT TO  
ZERO EMISSIONS

8

ST AROUND  
EUROPE

10

FOCUS ON  
R&D

12

INNOVATION

14

SCRAP & RAW  
MATERIAL TRETMENT

17

CHARGING &  
SKIMMING

19

MELTING &  
HOLDING

21

ADDITIONAL  
TECHNOLOGIES

22

METAL  
REFINING

25

CASTING

28

ADDITIONAL TECHNOLOGIES  
FOR CAST HOUSES

29

HEAT TREATMENT  
AFTER CASTING

30

HEAT TREATMENT  
AFTER PLASTIC

33

SOLUTIONS FOR  
COMPOSITES

35

AFTER SALES  
SERVICES

36

OUR  
REFERENCES

38

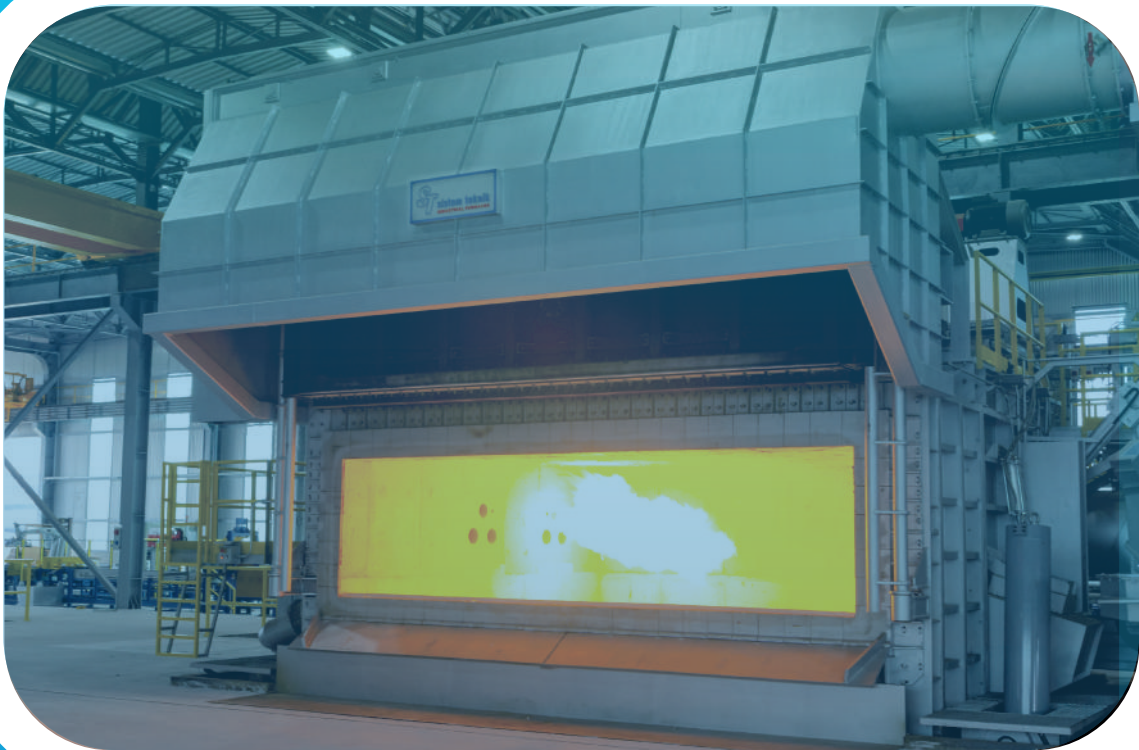

## **ENGINEERING EXCELLENCE BUILDING TRUST**

# SUSTAINABILITY IN THE ALUMINIUM INDUSTRY:

The aluminum industry has a long history of resource-intensive production processes. Although high energy consumption has been the norm in the past, the industry has made significant investments for environmentally friendly and sustainable technologies. This includes utilizing novel industrial techniques, investigating the utilization of renewable or low-carbon energy sources, and lowering waste and emissions.

At Sistem Teknik, we put sustainability at the center of our strategic decisions. In the past 5 years, Sistem Teknik has dedicated 85% of its R&D budget to reducing emissions in aluminum production, with efforts culminating in the development of 5 new equipment for the aluminum melting and heat treatment processes. These products include delacquering drum furnaces, preheating ovens targeting heat recuperation, camera integration systems for efficiency predictions, ultra-low NOx burners, and fully automated charging and skimming mechanisms in cast houses that shorten melting cycles.

The shift of the aluminum sector toward sustainability has been significantly aided by automation, IoT, AI, and machine learning. Digital integration has not only benefited companies in terms of efficiency and cost reduction, but it also added a security and safety dimension to the business by eliminating human intervention.

As one of the largest technology suppliers for the global aluminum industry, we have taken a leading role in revolutionizing the aluminum industry away from conventional production methods, known for their inefficiency and dependence on manual operations. Sistem Teknik has been working on image processing and machine learning solutions since 2019 and currently applies them to provide burner optimization, metal yield maximization, and data on alloying.

“

*For Sistem Teknik, sustainability is not only about reducing emissions but also about being able to continue designing and producing the future of the aluminum industry.*

”

## ALUMINUM RECYCLING FACTS



30

30 million tons of aluminum recycled annually



95

Recycling aluminum saves 95% of the energy required to produce primary aluminum



75

75% of the commercial aluminum produced since the 19<sup>th</sup> century is still in use.



∞

With closed-loop recycling, aluminum becomes infinitely reusable. This is why our current research focus is on laser technologies for liquid metal analysis and machine learning solutions for recycling efficiency in cast houses.

# ABOUT ST

Sistem Teknik was established in 1979 as a start-up company by two college friends from the Middle East Technical University, Orhan Obalı, and Mehmet Özdeşlik. With the initiatives of Orhan Obalı, ST has begun specializing in the design and production of heat treatment technology for light metals and composites in 2009 and worked ever since with a clear ambition: revolutionizing the aluminum industry towards a greener future. His ambition has guided us to become one of the largest technology providers for the aluminum industry with over 1500 furnaces operating in 36 countries. centre will continue to engineer the future of the aluminum industry.



At Sistem Teknik, we offer turnkey solutions from scrap pre-treatment to dross processing while granting the flexibility of in-house manufacturing. We automatize production lines for maximum performance and make sure that our products require minimum care. In a nutshell, we deliver simplicity. We design tailor-made products while offering a wide portfolio of equipment for melting, alloying, casting, homogenising, and heat treatment. In addition to design and commissioning, we provide after-sales services that prolong equipment lifetime.



In 2020, we opened a new chapter in ST's history with a new plant in Bulgaria and expanded our production line beyond borders. Having started with the modest goal of producing 1 furnace per month, our operations in Bulgaria are getting stronger with the opening of our new factory in Plovdiv by the end of 2023. Adding to the strength of our team in Turkey, we now house 300 engineers and technicians with a production capacity that has doubled in the past 5 years.

The next chapter is the opening of the ST Center of Innovation in Berlin which will increase our R&D capabilities and help us towards our goal of reducing the environmental impact of the aluminum industry. Ranging from fully automated dross skimmers and low NOx regenerative burners to IoT solutions, we have completed numerous R&D projects in the past 5 years. Having already developed new equipment for the recycling process with partners from the Horizon EU platform, Sistem Teknik R&D centre will continue to engineer the future of the aluminum industry.

“

*Sistem Teknik is one of the largest suppliers of furnace technology around the world. With a dedication to innovation and sustainability, we deliver turnkey solutions that aim to revolutionize the aluminum industry.*

”

## COMMITMENT TO NET ZERO CARBON EMISSIONS

Sistem Teknik has been dedicated to developing greener ways of recycling and processing aluminum since 2018. In 2020, our R&D center was awarded a partnership in the Retrofeed project funded by the European Commission under the Horizon Europe platform. In line with the projects requirements, Sistem Teknik delivered a smart retrofitting framework powered by state-of-the-art equipment and innovative software for aluminum cast houses. Various equipment such as oxygen injection systems, ultra-low NOx regenerative burners, and delacquering drum furnaces were commissioned in the demo-site, ASAŞ Aluminum. This project was only the first step in our journey toward achieving the ability to deliver cast houses and heat treatment plants with zero emissions.





As part of our roadmap for the Green Deal and its policy on the aluminum industry, our engineering team has started a project focused on detecting and minimizing the carbon footprint associated with all our products. By December 2023, we will be able to quantify, monitor, and validate the carbon footprint of our products according to ISO 14064 standards.

In addition to the innovations we apply to our technology, we will further improve our performance on climate reduction by using solar energy in our new plant in Plovdiv, Bulgaria.

“

*As most of our R&D work focuses on recycling technology, our fundamental goal is to make the aluminum industry eco-friendlier.*

”

## ST IN EUROPE

As Sistem Teknik, we have been committed to the continuous improvement of not only our products but also our production, logistics, and commissioning operations. Our focus on enhancing these core areas reflects our dedication to providing top-tier services to our global partners. In line with this commitment, we expanded our operations to Plovdiv, Bulgaria, in 2021, a strategic step aimed at bolstering our presence in the European market.



Recognizing the importance of this location to our company's future, we made the significant decision to open a new factory in Plovdiv. By the end of 2023, our state-of-the-art facility was fully operational, marking a major milestone in our journey of growth and expansion. Since the factory's opening, we have successfully completed the manufacturing of equipment for several major projects, reinforcing our ability to meet the demands of our European partners.

Our workforce has also expanded, now boasting a talented team of 60 engineers and technicians, all dedicated to delivering excellence. This expansion has enabled Sistem Teknik to significantly increase its capacity, allowing us to install equipment at more than 10 customer sites simultaneously.

The new facility features a sprawling 6,000 m<sup>2</sup> production area, specifically designed to optimize our manufacturing processes and enhance efficiency. With 17,000 m<sup>2</sup> of storage space, we are well-equipped to manage large-scale projects and inventory, ensuring seamless execution and timely delivery. Additionally, our modern office spaces provide a collaborative environment for our engineering teams, fostering innovation and teamwork as we continue to push the boundaries of what we can achieve.

This expansion not only strengthens our operational capabilities but also positions us to continue growing in the years to come, delivering even greater value to our clients.



## FOCUS ON R&D

Sistem Teknik is committed to developing innovative solutions that address the pressing environmental challenges the industry is facing. We are proud to announce the launch of our latest products that utilize the latest laser technologies and novel software solutions.

### LASER-INDUCED BREAKDOWN SPECTROSCOPY UNLOCKS NEW LEVELS OF EFFICIENCY

LIBS

One of our latest R&D projects on Laser-Induced Breakdown Spectroscopy (LIBS) has recently been awarded for funding by the Scientific and Technological Research Council of Turkey, TÜBİTAK. We improve furnace efficiency and metal quality in foundries by incorporating the LIBS system into our cast houses for the safer, faster, and greener production of aluminum. LIBS allows liquid metal analysis inside melting and holding furnaces.

With the Development of LIBS technology, we will be able to provide aluminum producers with the option of determining the in-situ chemical composition during the melting process. Sample collection for elemental analysis is made by fully automated systems with a no-man-on-the-ground perspective to ensure operational health and safety.

We consider LIBS to be imperative for the future of the aluminum industry as it shortens casting cycles by up to 40 minutes and therefore significantly reduces the emission of greenhouse gases and energy consumption and delivers foolproof alloying since the analysis takes place when the metal is in liquid form.



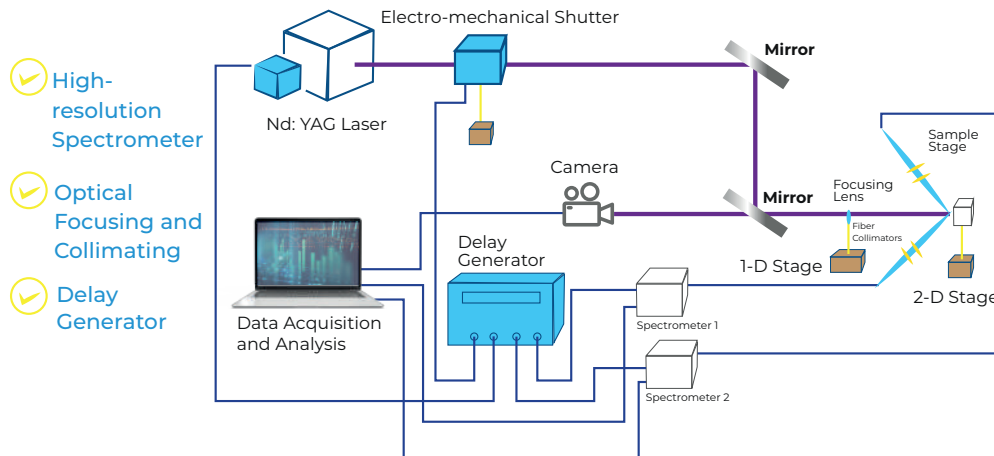

## HOW DOES THE LIBS SYSTEM WORK?

The probe is immersed to the required depth in molten metal

The probe is filled with pressurized argon gas to prevent liquid metal to fill the probe

The laser is propagated through the probe and focused onto the liquid metal

A spectrometer is used to measure the emission that occurs in a liquid metal

According to this measurement, the elements' proportions are measured

After the measurement, missing elements are detected with regards to the prescription

“

*Established in 2022, Sistem Teknik Advanced Research Laboratories focus on developing new laser technologies and implementing them to aluminum recycling and processing.*

”

# INNOVATION

By fostering a mindset that prioritizes innovation, Sistem Teknik has implemented a robust system for closely tracking and staying abreast of the latest technological trends. This approach enables us to proactively develop bespoke solutions that cater to the unique needs of our discerning customers within our target market, while also forging enduring partnerships through the execution of long-term projects. Our unyielding commitment to continuous improvement has enabled us to remain at the forefront of technological advancement, ensuring that our customers receive best-in-class service and solutions that exceed their expectations.

Our R&D Center continues its studies, especially focusing on smart factories that can work independently of human interactions and interventions. Our goal is to make foundries a more manageable place by developing safer, faster, and more efficient systems. In addition, our studies on artificial intelligence applications for operational excellence are continuing.

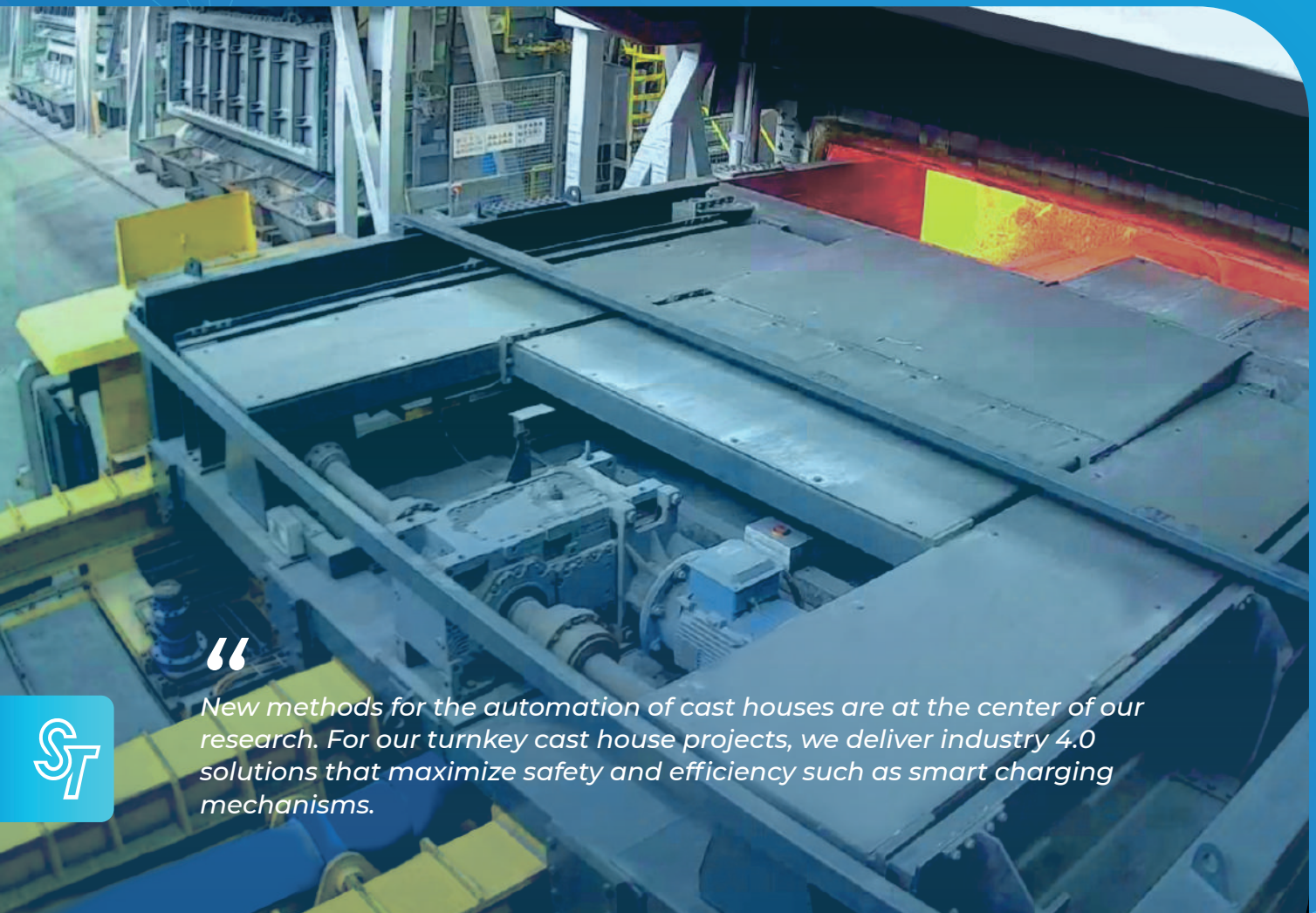

“

*New methods for the automation of cast houses are at the center of our research. For our turnkey cast house projects, we deliver industry 4.0 solutions that maximize safety and efficiency such as smart charging mechanisms.*





“

*Sistem Teknik R&D center recently developed a fully-automated skimming machine that utilizes image processing to detect dross formation. Now, it is one of the most sought-after equipment we offer to aluminum producers.*

With a young and energetic team of 65 engineers and designers, Sistem Teknik R&D center is an innovative working environment. More than 60% of the products we have delivered in the past three years were developed as a result of R&D projects. As most of our R&D work focuses on recycling technology, our fundamental goal is to make the aluminum industry eco-friendlier.

# SOLUTIONS WE PROVIDE FOR THE ALUMINUM INDUSTRY

## SCRAP AND RAW MATERIAL PRE-HEAT TREATMENT

- Delacquering Furnaces
- Preheating Furnaces
- Chip Drying Furnaces

## CHARGING AND SKIMMING

- Charging Cars
- Skimming Machines
- Dross Presses

## MELTING AND HOLDING

- Multi Chamber Furnaces
- Single Chamber Melting Holding Furnaces
- Electromagnetic Stirrers
- Chip Remelting Furnaces
- Filter and Baghouse Systems
- O<sub>2</sub> Injection Systems
- ST Phoenix Regenerative Burners
- Vortex Systems
- Smart Camera Systems
- Electromagnetic Pumps
- Sound Insulation Systems
- Porous Plugs

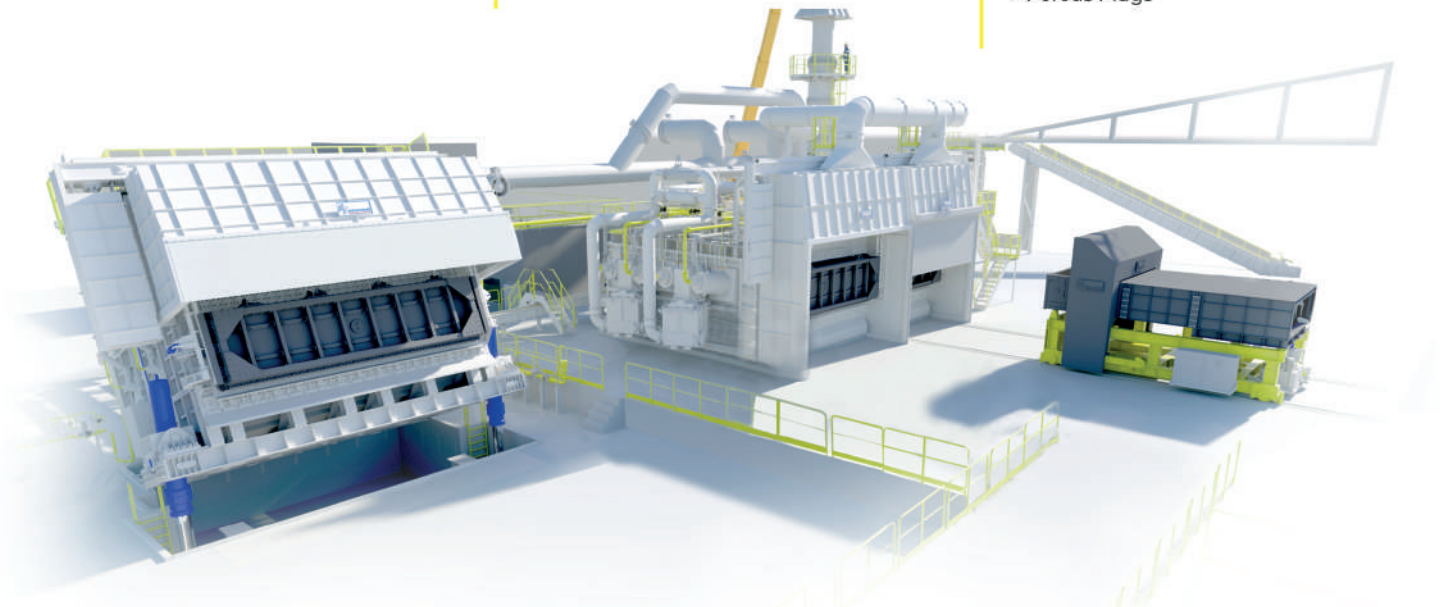

## METAL REFINING AND ALLOYING

- Launder Systems
- Rod Feeders
- Degassing Units
- Ceramic Foam Filters
- Laser Induced Breakdown Spectroscopy (LIBS)

## HEAT TREATMENT AFTER CASTING

- Continuous or Batch Type Homogenizing Furnaces
- Automated Stacking Systems
- Billet Laser Marking Mechanisms
- Hot Shears and Saws
- Billet Heating Furnaces
- Solution Heat Treatment Lines
- Continuous T6 Heat Treatment Lines
- Slug Annealing Lines for Aerosole Products

## HEAT TREATMENT AFTER PLASTIC DEFORMATION

- Coil/Foil Annealing Lines
- Drop Bottom and Ageing Ovens for Forged Aluminum Products



## SCRAP & RAW MATERIAL TREATMENT

### DELACQUERING FURNACES

- ◆ Metal yield from decoated scrap increased to 92%
- ◆ Superior melting capacity and energy efficiency with the hot scrap feed
- ◆ Lower emissions and energy costs with heat recuperation
- ◆ Unique design to prevent dust formation inside the factory





## PREHEATING CHAMBERS

- ◆ Using exhaust gases from melting furnaces, requiring no additional combustion system
- ◆ Reducing energy consumption by 25-200 kWh/ton in cast houses depending on the applied technology
- ◆ Aluminum material heated to 150-200°C, eliminating water and explosion risks

## CHIP DRYING FURNACES

- ◆ Chips cleaned of oily substances before being put into a vortex system
- ◆ Working in conjunction with the vortex system to dry chips
- ◆ Waste heat recovery helping reduce energy consumption and costs
- ◆ Maximized efficiency and minimized waste with the integration with the vortex system

## CHARGING & SKIMMING

### CHARGING CARS

- ◆ Fully automatic systems with up to 20 tons of capacity
- ◆ Wireless communication, electrical motor drive, and frequency controller for operational safety
- ◆ With unidirectional or bidirectional options

### CHIP FEEDING SYSTEMS

- ◆ Integrated to chip drying furnaces
- ◆ Dried chips are transferred in the vortex system with the assistance of the feeding system where they interact with the molten aluminum.





## SKIMMER

- ◆ Improved alloy quality and operational safety achieved with fully automated process
- ◆ High-temperature cameras, machine learning, and PLC systems used to detect and remove dross from the aluminum bath
- ◆ Telescopic lever designed for maneuverability to prevent refractory damage



## MELTING & HOLDING

### SINGLE & MULTI CHAMBER MELTING FURNACES

- ◆ Up to 150 tons capacity and melting rate of 20 tons per hour, energy consumption as low as 500 kW/ton
- ◆ Multi-chamber furnaces with continuous transfer of molten metal to ensure temperature uniformity and highest alloying quality
- ◆ Oxygen injection and pyrolysis systems for energy recovery and increased tolerance for scrap
- ◆ Patented door design for maximum fuel efficiency



## ADDITIONAL TECHNOLOGIES FOR CAST HOUSES

### ST PHOENIX: ULTRA LOW NO<sub>x</sub> REGENERATIVE BURNERS

- ◆ Integrated to the control and automation system and are suitable for most European standard furnaces
- ◆ Burner heads designed to tolerate contaminated scrap and reduce the dross rate
- ◆ Burner has quick-change design, making it easy to maintain and change

### O<sub>2</sub> INJECTION SYSTEMS

- ◆ O<sub>2</sub> injection systems to increase the immediate O<sub>2</sub> levels after scrap charging to reduce the emission of greenhouse gases



“

*Camera integration greatly contributes to safe and efficient production especially in multi-chamber furnaces.*

## CAMERA INTEGRATION SYSTEMS

- ◆ Utilized for analyzing the melting cycle inside the furnaces and
- ◆ Integrated to software that uses visual data for predicting melting time and dross formation

## ELECTROMAGNETIC PUMPS & VORTEX WELLS

- ◆ Utilized in new furnaces as well as existing ones to improve the efficiency of the degassing process
- ◆ Used for multi-chamber furnaces to transfer molten metal between different chambers and recycle aluminum chips
- ◆ Designed for fully automated operation and provide high alloying quality and temperature uniformity

## POROUS PLUG SYSTEMS

- ◆ Improve the mixing process and pre-gas the aluminum before casting
- ◆ Using argon or nitrogen gas that pass through liquid aluminum to form bubbles that rise to the surface

## ACOUSTIC CHAMBERS

- ◆ Significant reduction in noise levels
- ◆ Reduced crowding above furnaces
- ◆ Designed to be highly maneuverable and easy to install
- ◆ Risk of occupational accidents minimized, creating a safer working environment for foundry workers

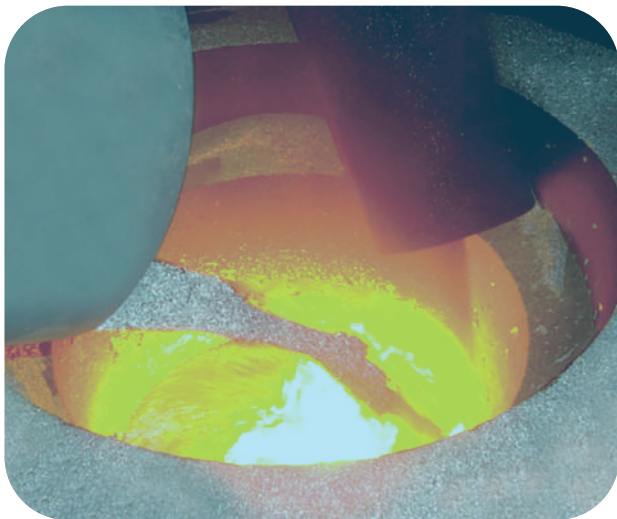

## VORTEX SYSTEM

- ◆ Aluminum sawdust processed before being added to the melting furnace to reduce oxide formation and metal loss
- ◆ Oil/moisture content is reduced to 0.5% to minimize metal loss
- ◆ Chips continuously charged with capacity of 2 to 5 tons/hour after moisture and hydrocarbons are removed
- ◆ Chips quickly submerged in liquid metal to minimize metal loss, resulting in a loss of less than 1%

## AIR FILTERS & BAGHOUSE SYSTEMS

- ◆ Waste gases from melting process transferred through an underground chimney to a filter baghouse
- ◆ Toxic gases in the waste gases are cleaned by the filter system

## METAL REFINING

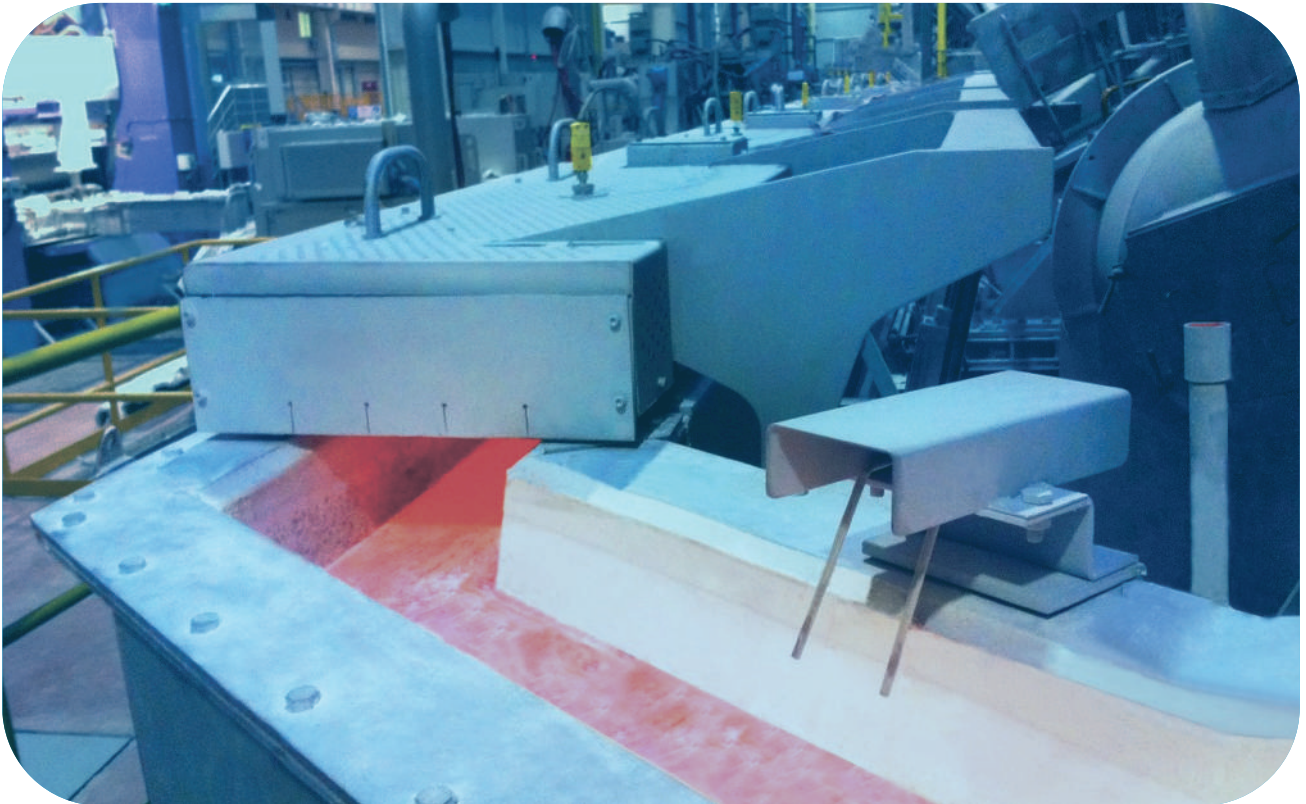

### HEATED LAUNDERS

- ◆ Electric or gas-fired launders designed for transferring molten aluminum between furnaces and casting machines
- ◆ Sizes range from 2 to 50 tons/hour and can be customized to meet unique needs
- ◆ Multiple layers of insulating materials ensure quality and safety, with pneumatic actuation used for easy cleaning

### ROD FEEDERS

- ◆ Designed to meet specific requirements for grain refinement and alloying
- ◆ Feeding speed is controlled by an AC motor
- ◆ Feed control can be performed manually via the unit's control panel or via the PLC in the casting machine control system



## DEGASSING UNITS

- ◆ Used for refining molten aluminum from hydrogen, inclusions, and alkalis
- ◆ Rotating system allows for easy maintenance in stationary degassers

## CFF FILTERING

- ◆ CFFs filter molten aluminum, avoid dross and impurities, regulate the molten aluminum flow, and improve the quality of aluminum alloys
- ◆ Capacity of 2-50 tons/hour of molten aluminum

## ELECTROMAGNETIC STIRRERS

- ◆ Stirrers speed up the melting process and minimize dross formation
- ◆ Stirring process is carried out without human intervention
- ◆ Electromagnetic field is established with inductors situated beneath the furnace to maintain homogenous heat distribution
- ◆ 15% energy savings due to the ease of maintenance and the elimination of the need to open the furnace door



“

*Electromagnetic stirring provides efficient mixing, improving furnace productivity more than 30% as the dross formation is also reduced significantly.*

## CASTING

### BILLET VERTICAL CHILL CASTING

- ◆ Casting capacity of up to 35 tons
- ◆ Casting operations that are simple and safe, with improved quality
- ◆ Control systems for automatic casting

### SLAB VERTICAL DIRECT CHILL CASTING

- ◆ Casting capacity ranging from 10 to 50 tons per drop
- ◆ Reduced scalping thickness prior to heat treatment and rolling
- ◆ Transducer used to ensure consistent casting quality and safety

### SINGLE BELT STRIP CASTING

- ◆ Aluminum ingots cast by feeding liquid metal between a water-cooled steel belt and a casting wheel
- ◆ Solidified sheet aluminum subjected to plastic deformation by entering the hot rolling mill
- ◆ Aluminum sheet thickness reduced in the hot rolling mill

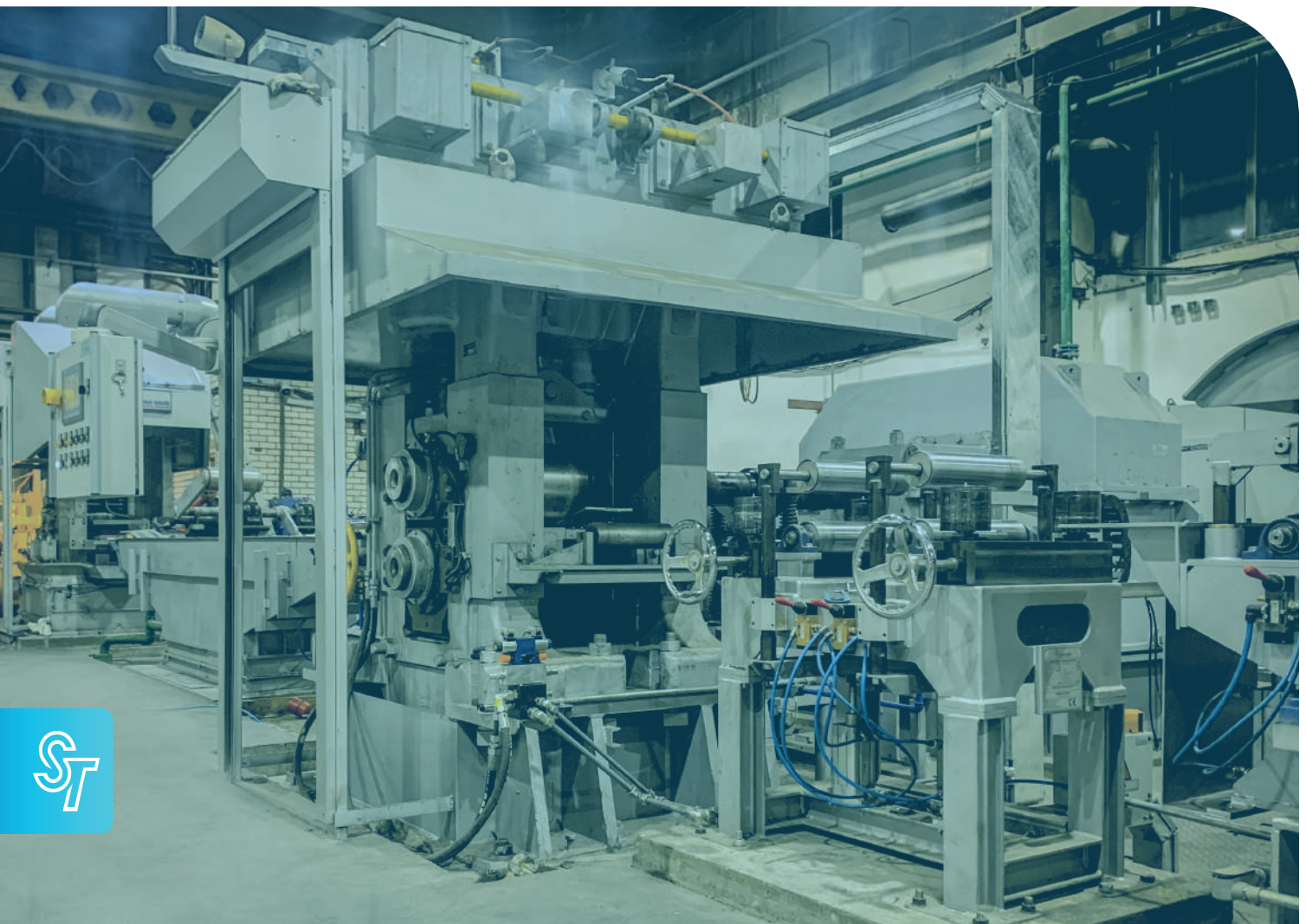



## INGOT CASTING MACHINES

- ◆ Before casting, a heating process is used to eliminate the risk of an explosion
- ◆ Primary cooling options include air or water (air-cooling is preferred for preventing cracks due to lower cooling rate)
- ◆ Casting capacity for 5-20 kg ingots ranges from 4 to 16 tons/hour
- ◆ A star-shaped automatic casting wheel designed to reduce surface oxidation
- ◆ Ingots are stacked, weighed, and labeled by the robot after the casting process

### ADDITIONAL EQUIPMENT

## TIP HEATING OVENS

- ◆ Determining the width of aluminum sheet during continuous strip casting.
- ◆ Utilized for the preheating of casting tips



## HEAT TREATMENT AFTER CASTING

### BATCH TYPE HOMOGENISING LINES

- ◆ Temperature homogeneity of  $\pm 5^{\circ}\text{C}$
- ◆ Capacities ranging from 10 to 110 tons/charge
- ◆ Integrated with transfer cars and cooling cabinets (cooling speed  $3^{\circ}\text{C}$  to  $4.5^{\circ}\text{C}$  per min)



### CONTINUOUS TYPE HOMOGENISING LINES

- ◆ Temperature homogeneity of  $\pm 3^{\circ}\text{C}$
- ◆ Process time cut in half compared to batch type furnaces
- ◆ Fully automated process flow from the entrance conveyor to the packing system
- ◆ Furnace capacity up to 18 tons/hour

## BILLET HEATING FURNACES

- ◆ Direct gas heating system with pre-mix jet type nozzle burners
- ◆ Gas consumption as low as 18 Nm<sup>3</sup>/ton with the special design of the nozzles
- ◆ Low thermal mass materials with low heat retention capacity used for insulation to ensure energy efficiency while also preventing melts
- ◆ Roller conveyors designed to operate in tandem with saws/shears



## STACKING & SAWING

- ◆ Hot saws recommended for diameters greater than 9 inches
- ◆ Shears recommended for diameters between 4 and 9 inches
- ◆ Hot shears have a double cutting system cutting billets with zero waste

## DROP BOTTOM FOR CAST ALUMINUM

- ◆ More than 100 projects completed around Europe
- ◆ Heat treatment and quenching incorporated into one controllable operation
- ◆ Short quench delay periods, 7 seconds for quenching including the time needed for the opening of the door
- ◆ Capability of rising the temperature levels from 20°C to 540°C in 90 min





## CONTINUOUS T6 FOR CAST ALUMINUM

- ◆ Fully automated continuous process with annealing, quenching, and ageing
- ◆ Temperature homogeneity less than  $\pm 5^{\circ}\text{C}$
- ◆ Energy-efficient self-recuperating burner systems
- ◆ Automated temperature control with a valve system and a smart circular airflow system
- ◆ Ageing process using the exhaust gases released from the heat treatment unit to minimise energy consumption (The temperature of the exhaust gas that the heat treatment unit burners produce varies from  $300$  to  $350^{\circ}\text{C}$ . Instead of releasing it to the atmosphere, the collector transfers this gas to the ageing unit to maintain the oven temperature at  $160^{\circ}\text{C}$ .)
- ◆ Energy use reduced by 25% compared to conventional production methods

# HEAT TREATMENT AFTER PLASTIC DEFORMATION

## AGEING OVENS

- ◆ More than 200 project completed around Europe
- ◆ Up to 24 baskets with single-length (8 m) and double-length (16 m) options
- ◆ Fully automated system equipped with smart loading cars
- ◆ Temperature homogeneity within  $\pm 3^{\circ}\text{C}$  tolerance with the use of a continuously reversible air flow system



## CONTINUOUS SLUG ANNEALING OVENS

- ◆ Fully automated system from the receipt of the slug to the packaging process
- ◆ Continuous charge to the furnace with a capacity of 2 to 6 tons/hour
- ◆ The desired temperature uniformity remains within a  $+5^{\circ}\text{C}$  tolerance
- ◆ Based on requirements, indirect gas heating (with self-recuperator burners and radiant tubes) or electric heating automated multi-directional smart charging cars are also offered





## COIL/FOIL ANNEALING FURNACES

- ◆ Retrofitting framework for the heating system to reduce energy consumption up to %40 compared to conventional production methods.
- ◆ Innovative nozzle design for optimum heat transfer (patented technology)
- ◆ N<sub>2</sub> atmosphere with O<sub>2</sub> levels less than 0.1%
- ◆ Temperature homogeneity of  $\pm 4^{\circ}\text{C}$
- ◆ Electrical or indirect gas heating
- ◆ For homogenising, intermediate, and final annealing

## COIL TRANSFER CARS

- ◆ Semi-automatic or fully automatic charging cars have loading capacities ranging from 10 to 120 tons and a sturdy steel construction
- ◆ Controlled by a laser encoder and limit switches for side positioning
- ◆ Wireless communication for all operations

## SOLUTIONS FOR COMPOSITES

### SAME QUALIFIED RESIN TRANSFER MOLDING (SQRTM)

- ◆ Closed molding method that produces perfect net-shape and highly modular aerospace components
- ◆ Quality and mechanical performance of the final product are enhanced by the injected resin, which provides hydrostatic pressure in the composite laminate and prevents the formation of void contents

### AUTOCLAVES FOR COMPOSITES

- ◆ Patented technology for reinforced honeycomb matrix materials
- ◆ Up to 20 meters in length with process values as high as 450°C and 21 bars

### CURING OVENS

- ◆ Achieving the stringent requirements of aerospace and defense industries
- ◆ Multi-section vertical air flow systems for temperature uniformity



# AFTER SALES SERVICES

---

Aluminum production requires reliability. Foundries and heat treatment lines need long-term solution partners that deliver efficiency, safety, and continuity. With over 40 years of experience as a turnkey solution partner and more than 1,500 operating furnaces commissioned in 36 countries, Sistem Teknik provides after-sales services for the maintenance and modernization of heat treatment and melting plants for the aluminum industry. An expert team of 25 engineers and technicians are dedicated to answer requests for preventative maintenance, repair, upgrading, staff training, and spare parts provision twenty-four hours a day, seven days a week. Moreover, we provide Occupational Health and Safety training at client sites on an annual basis to guarantee ongoing development and staff awareness and undertake routine risk assessments.





**Sistem Teknik After Sales team provides global support, responding to requests 24/7.**

# ST WITH NUMBERS

**SPECIALIZED IN ALUMINUM  
MELTING & HEAT TREATMENT  
SINCE 1979**

**1700  
PROJECTS COMPLETED IN  
36 COUNTRIES**

**315  
ENGINEERS AND EXPERTS IN  
BULGARIA, TURKEY, AND GERMANY**



## OUR REFERENCES

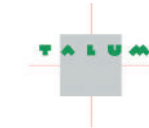

Lahikota prihodnosti





---

[www.sistemteknik.com](http://www.sistemteknik.com)  
[sales.alu@sistemteknik.com](mailto:sales.alu@sistemteknik.com)  
[service.alu@sistemteknik.com](mailto:service.alu@sistemteknik.com)

[in](#) [@](#) [f](#) / Sistem Teknik Industrial Furnaces Ltd